

New Product Announcement

October 1, 2009

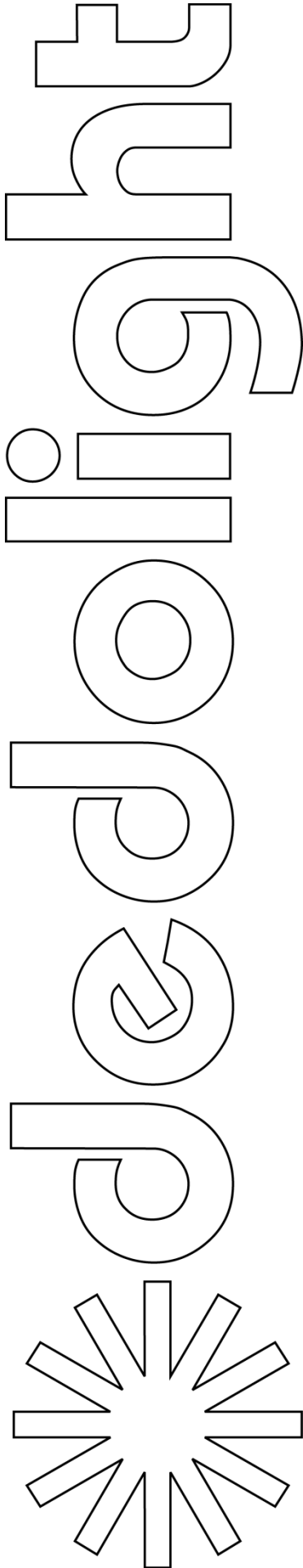

Another **NEW** product from Dedolight

Dedolight DBP Backpack

A very practical addition to our already existing portable studio product line (soft case lighting kits). The classic Dedolights as well as the 200 Series / SUNDANCE fixtures can be easily transported in this new and comfortable backpack.

The design of the backpack is simple, practical and is designed for functionality. The top and side handles guarantee maximum portability in any situation. An additional pouch on the side allows transporting soft boxes up to the size of a Dedolight 5 ft. Octodome (DSBOCT). If not needed during transport, the carrying

The inside construction serves only one important task – balance. The stand compartment is in the middle and the light head compartments are on the side. This guarantees a perfectly balanced and comfortable case. Two additional horizontal belts contribute to stability and security of the transported equipment and they are also used to secure the soft box.

Like all other Dedolight portable studio soft cases, this backpack is made of almost indestructible materials and stands up to the usual mistreatments which are characteristic of the daily work on film and TV sets.

This Dedolight backpack provides the major advantage of having both your hands free, while carrying your lighting kit.



light

dedo

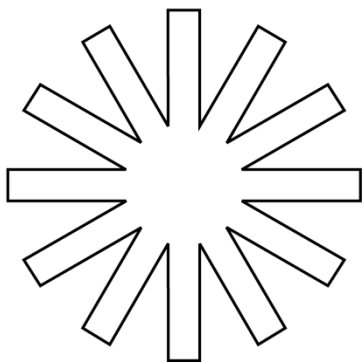

Open



Carrying belts



Contents – Classic series



Contents – Series 200

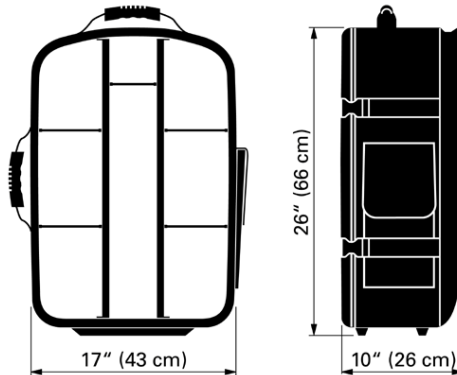

DBP BACKPACK Dimensions

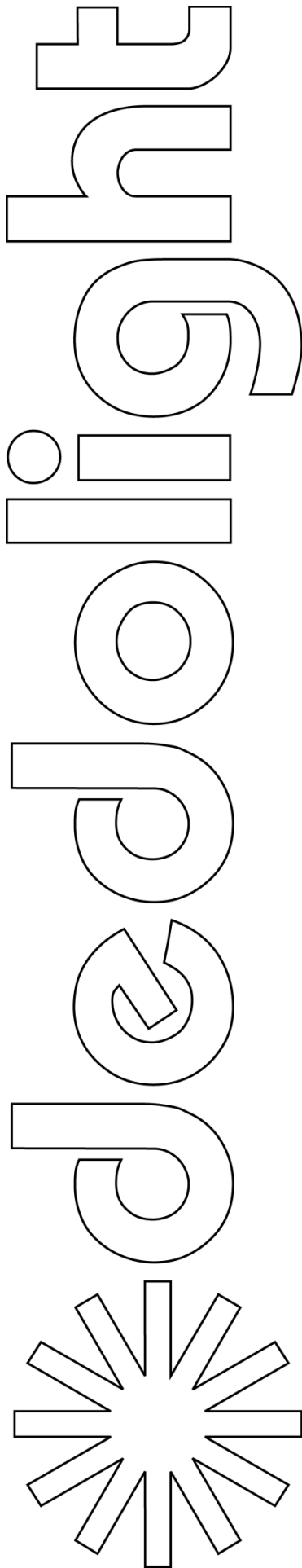

Technical Data:

**Dedolight Backpack
Catalog No.: DBP**

Outer size: 26" x 17" x 10.2" (66 x 43 x 26 cm)
Inner compartment sizes:

Stand compartment:
23.6" x 3.9" x 8.3"
(60 x 10 x 21 cm)

Fixture compartments (2 x):

Between:

19.6" and 23.6" x 5.5" x 8.3"
(50 and 60 x 14 x 21 cm)

All dividers are individually adjustable

Weight: 13.2 lbs. (6 kg)

Capacity: 4 x DST stands, 4 x DLHM4-300, up to a DLH1000SPLUS, spare lamps, small accessories and one soft box (up to a 5' Octodome).

OR

4 x DST stands, 3 x DLH4, up to one DLH1000SPLUS, 3 x in-line dimmable power supplies, spare lamps, small accessories and one soft box (up to a 5' Octodome).

OR

4 x DST stands, 2 x DLH200D, 1 x DLH200S, 3 x DEB200D, spare lamps, small accessories and one soft box (up to a 5' Octodome).



DEDOTEC USA, INC.

48 Sheffield Business Park
Ashley Falls, MA 01222

Tel: (413) 229-2550– Fax: (413) 229-2556

E-mail: info@dedolight.com

www.dedolight.com